

# Basic Graph Algorithms

(Based on [Manber 1989])

Yih-Kuen Tsay

Department of Information Management  
National Taiwan University

# The Königsberg Bridges Problem

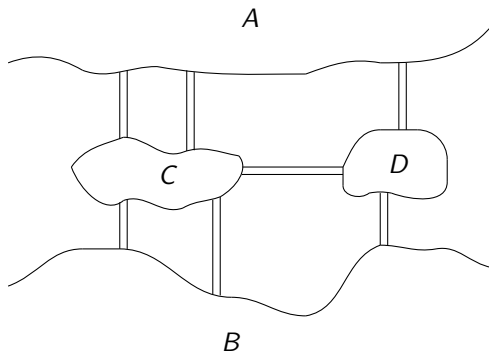

Figure: The Königsberg bridges problem.

Source: redrawn from [Manber 1989, Figure 7.1].

Can one start from one of the lands, cross every bridge exactly once, and return to the origin?

# The Königsberg Bridges Problem (cont.)

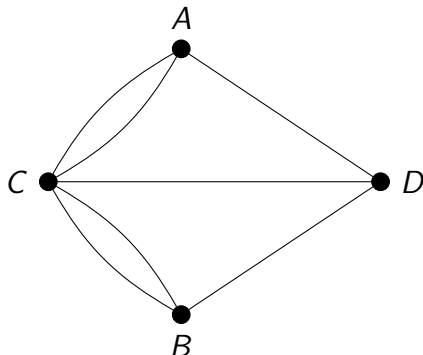

Figure: The graph corresponding to the Königsberg bridges problem.

Source: redrawn from [Manber 1989, Figure 7.2].

# Graphs



- 🌐 A graph consists of a set of **vertices** (or nodes) and a set of **edges** (or links, each normally connecting two vertices).
- 🌐 A graph is commonly denoted as  $G(V, E)$ , where
  - ☀  $G$  is the name of the graph,
  - ☀  $V$  is the set of vertices, and
  - ☀  $E$  is the set of edges.

# Graphs (cont.)



- 🌐 Undirected vs. Directed Graph
- 🌐 Simple Graph vs. Multigraph
- 🌐 Path, Simple Path, Trail
- 🌐 Circuit, Cycle
- 🌐 Degree, In-Degree, Out-Degree
- 🌐 Connected Graph, Connected Components
- 🌐 Tree, Forest
- 🌐 Subgraph, Induced Subgraph
- 🌐 Spanning Tree, Spanning Forest
- 🌐 Weighted Graph

# Modeling with Graphs



## Reachability

-  Finding program errors
-  Solving sliding tile puzzles

## Shortest Paths

-  Finding the fastest route to a place
-  Routing messages in networks

## Graph Coloring

-  Coloring maps
-  Scheduling classes

# Eulerian Graphs

## Problem

Given an undirected connected graph  $G = (V, E)$  such that all the vertices have *even degrees*, find a circuit  $P$  such that each edge of  $E$  appears in  $P$  exactly once.

The circuit  $P$  in the problem statement is called an *Eulerian circuit*.

## Theorem

An undirected connected graph has an Eulerian circuit *if and only if* all of its vertices have even degrees.

# Depth-First Search

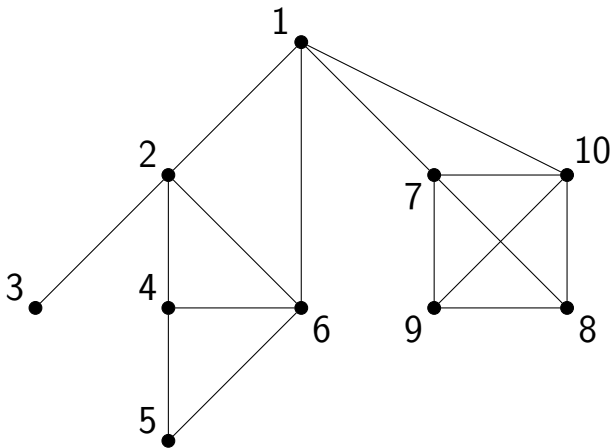

Figure: A DFS for an undirected graph.

Source: redrawn from [Manber 1989, Figure 7.4].



# Depth-First Search (cont.)

```
Algorithm Depth_First_Search( $G, v$ );  
begin  
    mark  $v$ ;  
    perform preWORK on  $v$ ;  
    for all edges  $(v, w)$  do  
        if  $w$  is unmarked then  
            Depth_First_Search( $G, w$ );  
        perform postWORK for  $(v, w)$   
end
```

# Depth-First Search (cont.)

```
Algorithm Refined_DFS( $G, v$ );  
begin  
  mark  $v$ ;  
  perform preWORK on  $v$ ;  
  for all edges  $(v, w)$  do  
    if  $w$  is unmarked then  
      Refined_DFS( $G, w$ );  
      perform postWORK for  $(v, w)$ ;  
  perform postWORK_II on  $v$   
end
```

# Connected Components

**Algorithm Connected\_Components( $G$ );**

**begin**

*Component\_Number* := 1;

**while** there is an unmarked vertex  $v$  **do**

*Depth\_First\_Search*( $G, v$ )

(preWORK:

*v.Component* := *Component\_Number*);

*Component\_Number* := *Component\_Number* + 1

**end**

# Connected Components

**Algorithm Connected\_Components( $G$ );**

**begin**

*Component\_Number* := 1;

**while** there is an unmarked vertex  $v$  **do**

*Depth\_First\_Search*( $G, v$ )

(preWORK:

*v.Component* := *Component\_Number*);

*Component\_Number* := *Component\_Number* + 1

**end**

Time complexity:

# Connected Components

**Algorithm Connected\_Components( $G$ );**

**begin**

*Component\_Number* := 1;

**while** there is an unmarked vertex  $v$  **do**

*Depth\_First\_Search*( $G, v$ )

(preWORK:

*v.Component* := *Component\_Number*);

*Component\_Number* := *Component\_Number* + 1

**end**

Time complexity:  $O(|E| + |V|)$ .

# DFS Numbers

```
Algorithm DFS_Numbering( $G, v$ );  
begin  
     $DFS\_Number := 1$ ;  
    Depth_First_Search( $G, v$ )  
    (preWORK:  
         $v.DFS := DFS\_Number$ ;  
         $DFS\_Number := DFS\_Number + 1$ )  
end
```

# DFS Numbers

```
Algorithm DFS_Numbering( $G, v$ );  
begin  
     $DFS\_Number := 1$ ;  
    Depth_First_Search( $G, v$ )  
    (preWORK:  
         $v.DFS := DFS\_Number$ ;  
         $DFS\_Number := DFS\_Number + 1$ )  
end
```

Time complexity:  $O(|E|)$  (assuming the input graph is connected).

# The DFS Tree

```
Algorithm Build_DFS_Tree( $G, v$ );  
begin  
    Depth_First_Search( $G, v$ )  
    (postWORK:  
        if  $w$  was unmarked then  
            add the edge  $(v, w)$  to  $T$ );  
end
```



# The DFS Tree (cont.)

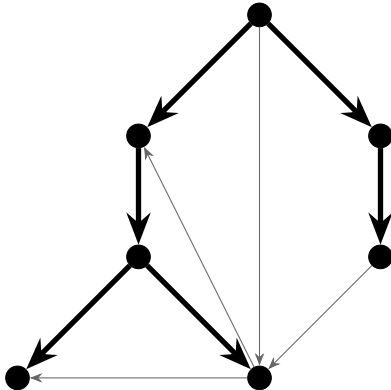

Figure: A DFS tree for a directed graph.

Source: redrawn from [Manber 1989, Figure 7.9].

# The DFS Tree (cont.)

## Lemma (7.2)

*For an undirected graph  $G = (V, E)$ , every edge  $e \in E$  either belongs to the DFS tree  $T$ , or connects two vertices of  $G$ , one of which is the ancestor of the other in  $T$ .*

For undirected graphs, DFS avoids **cross edges**.

## Lemma (7.3)

*For a directed graph  $G = (V, E)$ , if  $(v, w)$  is an edge in  $E$  such that  $v.DFS\_Number < w.DFS\_Number$ , then  $w$  is a descendant of  $v$  in the DFS tree  $T$ .*

For directed graphs, cross edges must go “**from right to left**”.

# Directed Cycles

## Problem

Given a directed graph  $G = (V, E)$ , determine whether it contains a (directed) cycle.

## Lemma (7.4)

$G$  contains a directed cycle if and only if  $G$  contains a *back edge* (relative to the DFS tree).

## Directed Cycles (cont.)

```
Algorithm Find_a_Cycle( $G$ );  
begin  
   $Depth\_First\_Search(G, v)$  /* arbitrary  $v$  */  
  (preWORK:  
     $v.on\_the\_path := true$ ;  
  postWORK:  
    if  $w.on\_the\_path$  then  
       $Find\_a\_Cycle := true$ ;  
      halt;  
    if  $w$  is the last vertex on  $v$ 's list then  
       $v.on\_the\_path := false$ );  
end
```

# Directed Cycles (cont.)

**Algorithm Refined\_Find\_a\_Cycle( $G$ );**

**begin**

*Refined\_DFS*( $G, v$ ) /\* arbitrary  $v$  \*/

(preWORK:

$v.on\_the\_path := true$ ;

postWORK:

**if**  $w.on\_the\_path$  **then**

$Refined\_Find\_a\_Cycle := true$ ;

halt;

postWORK\_II:

$v.on\_the\_path := false$ )

**end**

# Breadth-First Search

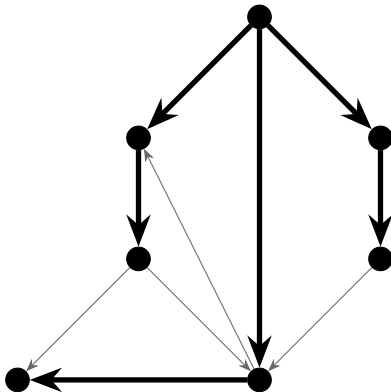

Figure: A BFS tree for a directed graph.

Source: redrawn from [Manber 1989, Figure 7.12].

# Breadth-First Search (cont.)

**Algorithm Breadth\_First\_Search**( $G, v$ );

**begin**

mark  $v$ ;

put  $v$  in a **queue**;

**while** the queue is not empty **do**

remove vertex  $w$  from the queue;

perform **preWORK** on  $w$ ;

**for** all edges  $(w, x)$  with  $x$  unmarked **do**

mark  $x$ ;

add  $(w, x)$  to the *BFS* tree  $T$ ;

put  $x$  in the queue

**end**

# Breadth-First Search (cont.)

## Lemma (7.5)

*If an edge  $(u, w)$  belongs to a BFS tree such that  $u$  is a parent of  $w$ , then  $u$  has the minimal BFS number among vertices with edges leading to  $w$ .*

## Lemma (7.6)

*For each vertex  $w$ , the path from the root to  $w$  in  $T$  is a shortest path from the root to  $w$  in  $G$ .*

## Lemma (7.7)

*If an edge  $(v, w)$  in  $E$  does not belong to  $T$  and  $w$  is on a larger level, then the level numbers of  $w$  and  $v$  differ by at most 1.*



# Breadth-First Search (cont.)

**Algorithm Simple\_BFS**( $G, v$ );

**begin**

put  $v$  in *Queue*;

**while** *Queue* is not empty **do**

remove vertex  $w$  from *Queue*;

**if**  $w$  is unmarked **then**

mark  $w$ ;

perform **preWORK** on  $w$ ;

**for** all edges  $(w, x)$  with  $x$  unmarked **do**

put  $x$  in *Queue*

**end**

# Breadth-First Search (cont.)

**Algorithm Simple\_Nonrecursive\_DFS( $G, v$ );**

**begin**

push  $v$  to *Stack*;

**while** *Stack* is not empty **do**

pop vertex  $w$  from *Stack*;

**if**  $w$  is unmarked **then**

mark  $w$ ;

perform **preWORK** on  $w$ ;

**for** all edges  $(w, x)$  with  $x$  unmarked **do**

push  $x$  to *Stack*

**end**

# Topological Sorting

## Problem

*Given a directed acyclic graph  $G = (V, E)$  with  $n$  vertices, label the vertices from 1 to  $n$  such that, if  $v$  is labeled  $k$ , then all vertices that can be reached from  $v$  by a directed path are labeled with labels  $> k$ .*

## Lemma (7.8)

*A directed acyclic graph always contains a vertex with indegree 0.*

# Topological Sorting (cont.)

**Algorithm Topological\_Sorting( $G$ );**

initialize  $v.indegree$  for all vertices; /\* by DFS \*/

$G\_label := 0$ ;

**for**  $i := 1$  to  $n$  **do**

**if**  $v_i.indegree = 0$  **then** put  $v_i$  in *Queue*;

**repeat**

    remove vertex  $v$  from *Queue*;

$G\_label := G\_label + 1$ ;

$v.label := G\_label$ ;

**for** all edges  $(v, w)$  **do**

$w.indegree := w.indegree - 1$ ;

**if**  $w.indegree = 0$  **then** put  $w$  in *Queue*

**until** *Queue* is empty

## Problem

*Given a directed graph  $G = (V, E)$  and a vertex  $v$ , find shortest paths from  $v$  to all other vertices of  $G$ .*

# Shorted Paths: The Acyclic Case

**Algorithm Acyclic\_Shortest\_Paths**( $G, v, n$ );  
{Initially,  $w.SP = \infty$ , for every node  $w$ .}  
{A topological sort has been performed on  $G, \dots$ }

**begin**  
  let  $z$  be the vertex labeled  $n$ ;  
  **if**  $z \neq v$  **then**  
    *Acyclic\_Shortest\_Paths*( $G - z, v, n - 1$ );  
    **for** all  $w$  such that  $(w, z) \in E$  **do**  
      **if**  $w.SP + \text{length}(w, z) < z.SP$  **then**  
         $z.SP := w.SP + \text{length}(w, z)$   
    **else**  $v.SP := 0$   
**end**

## The Acyclic Case (cont.)

```
Algorithm Imp_Acyclic_Shortest_Paths( $G, v$ );  
  for all vertices  $w$  do  $w.SP := \infty$ ;  
  initialize  $v.indegree$  for all vertices;  
  for  $i := 1$  to  $n$  do  
    if  $v_i.indegree = 0$  then put  $v_i$  in Queue;  
   $v.SP := 0$ ;  
  repeat  
    remove vertex  $w$  from Queue;  
    for all edges  $(w, z)$  do  
      if  $w.SP + length(w, z) < z.SP$  then  
         $z.SP := w.SP + length(w, z)$ ;  
         $z.indegree := z.indegree - 1$ ;  
        if  $z.indegree = 0$  then put  $z$  in Queue  
  until Queue is empty
```

# Shortest Paths: The General Case

```
Algorithm Single_Source_Shortest_Paths( $G, v$ );  
// Dijkstra's algorithm  
begin  
  for all vertices  $w$  do  
     $w.mark := false$ ;  
     $w.SP := \infty$ ;  
 $v.SP := 0$ ;  
  while there exists an unmarked vertex do  
    let  $w$  be an unmarked vertex s.t.  $w.SP$  is minimal;  
     $w.mark := true$ ;  
    for all edges  $(w, z)$  such that  $z$  is unmarked do  
      if  $w.SP + length(w, z) < z.SP$  then  
         $z.SP := w.SP + length(w, z)$   
end
```



# Shortest Paths: The General Case

```
Algorithm Single_Source_Shortest_Paths( $G, v$ );  
// Dijkstra's algorithm  
begin  
  for all vertices  $w$  do  
     $w.mark := false$ ;  
     $w.SP := \infty$ ;  
 $v.SP := 0$ ;  
  while there exists an unmarked vertex do  
    let  $w$  be an unmarked vertex s.t.  $w.SP$  is minimal;  
     $w.mark := true$ ;  
    for all edges  $(w, z)$  such that  $z$  is unmarked do  
      if  $w.SP + length(w, z) < z.SP$  then  
         $z.SP := w.SP + length(w, z)$   
end
```

Time complexity:

# Shortest Paths: The General Case

```
Algorithm Single_Source_Shortest_Paths( $G, v$ );  
// Dijkstra's algorithm  
begin  
  for all vertices  $w$  do  
     $w.mark := false$ ;  
     $w.SP := \infty$ ;  
 $v.SP := 0$ ;  
  while there exists an unmarked vertex do  
    let  $w$  be an unmarked vertex s.t.  $w.SP$  is minimal;  
     $w.mark := true$ ;  
    for all edges  $(w, z)$  such that  $z$  is unmarked do  
      if  $w.SP + length(w, z) < z.SP$  then  
         $z.SP := w.SP + length(w, z)$   
end
```

Time complexity:  $O((|E| + |V|) \log |V|)$  (using a min heap).

# The General Case (cont.)

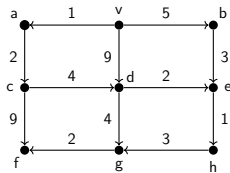

|   | v | a | b | c        | d | e        | f        | g        | h        |
|---|---|---|---|----------|---|----------|----------|----------|----------|
| a | 0 | 1 | 5 | $\infty$ | 9 | $\infty$ | $\infty$ | $\infty$ | $\infty$ |
| c | 0 | ① | 5 | 3        | 9 | $\infty$ | $\infty$ | $\infty$ | $\infty$ |
| b | 0 | ① | 5 | ③        | 7 | $\infty$ | 12       | $\infty$ | $\infty$ |
| d | 0 | ① | ⑤ | ③        | 7 | 8        | 12       | $\infty$ | $\infty$ |
| e | 0 | ① | ⑤ | ③        | ⑦ | 8        | 12       | $\infty$ | $\infty$ |
| h | 0 | ① | ⑤ | ③        | ⑦ | ⑧        | 12       | 11       | 9        |
| g | 0 | ① | ⑤ | ③        | ⑦ | ⑧        | 12       | 11       | ⑨        |
| f | 0 | ① | ⑤ | ③        | ⑦ | ⑧        | 12       | ⑪        | ⑨        |

Figure: An example of the single-source shortest-paths algorithm.

Source: redrawn from [Manber 1989, Figure 7.18].

# Minimum-Weight Spanning Trees

## Problem

Given an undirected connected weighted graph  $G = (V, E)$ , find a spanning tree  $T$  of  $G$  of minimum weight.

## Theorem

Let  $V_1$  and  $V_2$  be a partition of  $V$  and  $E(V_1, V_2)$  be the set of edges connecting nodes in  $V_1$  to nodes in  $V_2$ . The *edge with the minimum weight in  $E(V_1, V_2)$*  must be in the minimum-cost spanning tree of  $G$ .

# Minimum-Weight Spanning Trees (cont.)

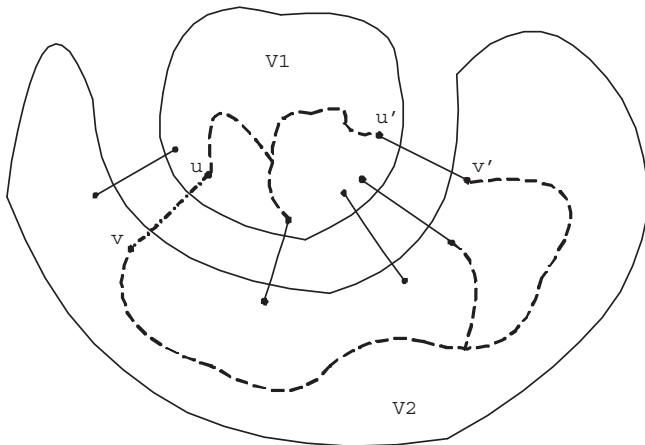

If  $cost(u, v)$  is the smallest among  $E(V_1, V_2)$ , then  $\{u, v\}$  must be in the minimum spanning tree.

# Minimum-Weight Spanning Trees (cont.)

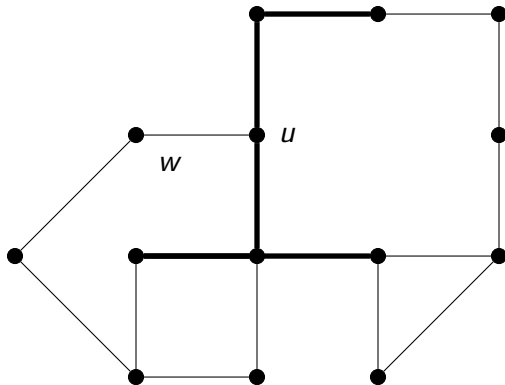

Figure: Finding the next edge of the MCST.

Source: redrawn from [Manber 1989, Figure 7.19].

# Minimum-Weight Spanning Trees (cont.)

**Algorithm MST( $G$ );**

// A variant of Prim's algorithm

**begin**

initially  $T$  is the empty set;

**for** all vertices  $w$  **do**

$w.mark := false$ ;  $w.cost := \infty$ ;

let  $(x, y)$  be a minimum cost edge in  $G$ ;

$x.mark := true$ ;

**for** all edges  $(x, z)$  **do**

$z.edge := (x, z)$ ;  $z.cost := cost(x, z)$ ;

# Minimum-Weight Spanning Trees (cont.)



```
while there exists an unmarked vertex do
  let  $w$  be an unmarked vertex with minimal  $w.cost$ ;
  if  $w.cost = \infty$  then
    print "G is not connected"; halt
  else
     $w.mark := true$ ;
    add  $w.edge$  to  $T$ ;
    for all edges  $(w, z)$  do
      if not  $z.mark$  then
        if  $cost(w, z) < z.cost$  then
           $z.edge := (w, z)$ ;  $z.cost := cost(w, z)$ 
end
```



# Minimum-Weight Spanning Trees (cont.)

**Algorithm Another\_MST( $G$ );**

// Prim's algorithm

**begin**

initially  $T$  is the empty set;

**for** all vertices  $w$  **do**

$w.mark := false$ ;  $w.cost := \infty$ ;

$x.mark := true$ ; /\*  $x$  is an arbitrary vertex \*/

**for** all edges  $(x, z)$  **do**

$z.edge := (x, z)$ ;  $z.cost := cost(x, z)$ ;

# Minimum-Weight Spanning Trees (cont.)

```
while there exists an unmarked vertex do  
  let  $w$  be an unmarked vertex with minimal  $w.cost$ ;  
  if  $w.cost = \infty$  then  
    print "G is not connected"; halt  
  else  
     $w.mark := true$ ;  
    add  $w.edge$  to  $T$ ;  
    for all edges  $(w, z)$  do  
      if not  $z.mark$  then  
        if  $cost(w, z) < z.cost$  then  
           $z.edge := (w, z)$ ;  
           $z.cost := cost(w, z)$   
end
```

# Minimum-Weight Spanning Trees (cont.)

```
while there exists an unmarked vertex do  
  let  $w$  be an unmarked vertex with minimal  $w.cost$ ;  
  if  $w.cost = \infty$  then  
    print "G is not connected"; halt  
  else  
     $w.mark := true$ ;  
    add  $w.edge$  to  $T$ ;  
    for all edges  $(w, z)$  do  
      if not  $z.mark$  then  
        if  $cost(w, z) < z.cost$  then  
           $z.edge := (w, z)$ ;  
           $z.cost := cost(w, z)$   
    end  
end
```

Time complexity:

# Minimum-Weight Spanning Trees (cont.)

```
while there exists an unmarked vertex do  
  let  $w$  be an unmarked vertex with minimal  $w.cost$ ;  
  if  $w.cost = \infty$  then  
    print "G is not connected"; halt  
  else  
     $w.mark := true$ ;  
    add  $w.edge$  to  $T$ ;  
    for all edges  $(w, z)$  do  
      if not  $z.mark$  then  
        if  $cost(w, z) < z.cost$  then  
           $z.edge := (w, z)$ ;  
           $z.cost := cost(w, z)$   
    end  
end
```

Time complexity: same as that of Dijkstra's algorithm.

# Minimum-Weight Spanning Trees (cont.)

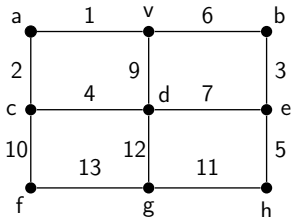

|   | v | a    | b    | c        | d    | e        | f        | g        | h        |
|---|---|------|------|----------|------|----------|----------|----------|----------|
| v | - | v(1) | v(6) | $\infty$ | v(9) | $\infty$ | $\infty$ | $\infty$ | $\infty$ |
| a | - | -    | v(6) | a(2)     | v(9) | $\infty$ | $\infty$ | $\infty$ | $\infty$ |
| c | - | -    | v(6) | -        | c(4) | $\infty$ | c(10)    | $\infty$ | $\infty$ |
| d | - | -    | v(6) | -        | -    | d(7)     | c(10)    | d(12)    | $\infty$ |
| b | - | -    | -    | -        | -    | b(3)     | c(10)    | d(12)    | $\infty$ |
| e | - | -    | -    | -        | -    | -        | c(10)    | d(12)    | e(5)     |
| h | - | -    | -    | -        | -    | -        | c(10)    | h(11)    | -        |
| f | - | -    | -    | -        | -    | -        | -        | h(11)    | -        |
| g | - | -    | -    | -        | -    | -        | -        | -        | -        |

Figure: An example of the minimum-cost spanning-tree algorithm.

Source: redrawn from [Manber 1989, Figure 7.21].

## Problem

*Given a weighted graph  $G = (V, E)$  (directed or undirected) with nonnegative weights, find the minimum-length paths between all pairs of vertices.*

# Floyd's Algorithm

**Algorithm All\_Pairs\_Shortest\_Paths( $W$ );**

**begin**

  {initialization}

**for**  $i := 1$  to  $n$  **do**

**for**  $j := 1$  to  $n$  **do**

**if**  $(i, j) \in E$  **then**  $W[i, j] := \text{length}(i, j)$

**else**  $W[i, j] := \infty$ ;

**for**  $i := 1$  to  $n$  **do**  $W[i, i] := 0$ ;

**for**  $m := 1$  to  $n$  **do** {the induction sequence}

**for**  $x := 1$  to  $n$  **do**

**for**  $y := 1$  to  $n$  **do**

**if**  $W[x, m] + W[m, y] < W[x, y]$  **then**

$W[x, y] := W[x, m] + W[m, y]$

**end**

# Transitive Closure

## Problem

Given a directed graph  $G = (V, E)$ , find its transitive closure.

```
Algorithm Transitive_Closure( $A$ );  
begin  
    {initialization omitted}  
    for  $m := 1$  to  $n$  do  
        for  $x := 1$  to  $n$  do  
            for  $y := 1$  to  $n$  do  
                if  $A[x, m]$  and  $A[m, y]$  then  
                     $A[x, y] := true$   
end
```



# Transitive Closure (cont.)

**Algorithm Improved\_Transitive\_Closure( $A$ );**

**begin**

{initialization omitted}

**for**  $m := 1$  to  $n$  **do**

**for**  $x := 1$  to  $n$  **do**

**if**  $A[x, m]$  **then**

**for**  $y := 1$  to  $n$  **do**

**if**  $A[m, y]$  **then**

$A[x, y] := true$

**end**